

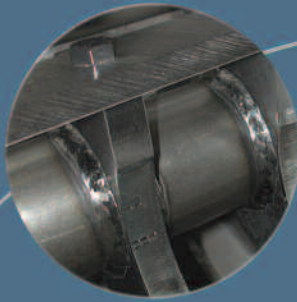

800X Series Beside-the-Press Granulators

The 3 knife open slant cut rotor with scooped wings provide positive feed of bulky parts and improve airflow for cooler operation



Optional bolt on feed chutes to optimize feed of granulator. Feed Methods include: robot, conveyor, and profile feed chutes



Swing down clamp with hand knob provides quick and easy machine access



Fully removable screen cradle and bin allow for total access during cleaning



800X Series Offers Compact, Beside-the-Press Granulation

The 800X Series granulators are ideal for reject components from the injection, blow molding, and extrusion processes. The compact design makes them easily movable and the

sound enclosure controls noise and permits access.

Engineered for hand feed, robot feed or conveyor feed, these low speed granulators are packed full of standard features.

800X Series Beside-the-Press Granulators

Standard Features

- *Pivoting hopper, drop-down removable screen cradle and machined, bolted cutting chamber simplifies cleaning and maintenance*
- *Low profile, sound-attenuated infeed system for robot, hand or conveyor feed applications*
- *HCHC knives manufactured in-house utilizing Cumberland's proprietary process for heat-treating ensure durability and long life*
- *Oversized solid flywheel*

Options

- *Motor: 7.5 to 10 HP (5.5 to 7.5 kW) TEFC motors*
- *Discharge: 1.25", 1.5", 2" or 2.5" vacuum take-off*
- *Knives: D2 components and wear-resistant package for abrasive applications*
- *Modular feed chutes*

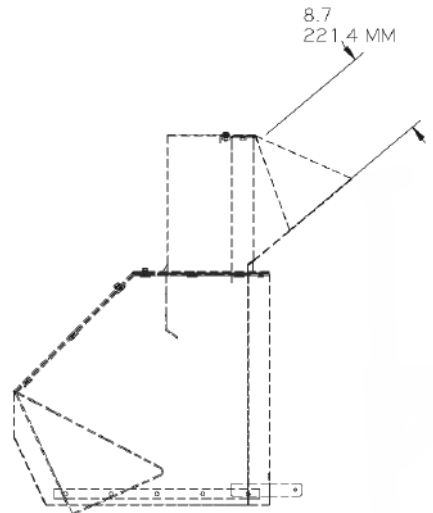
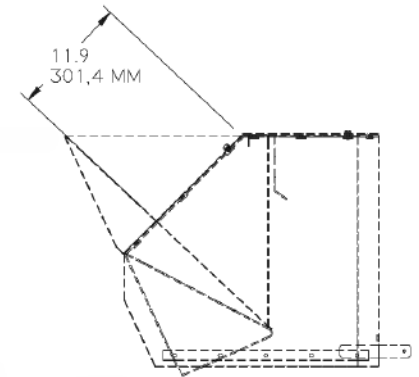
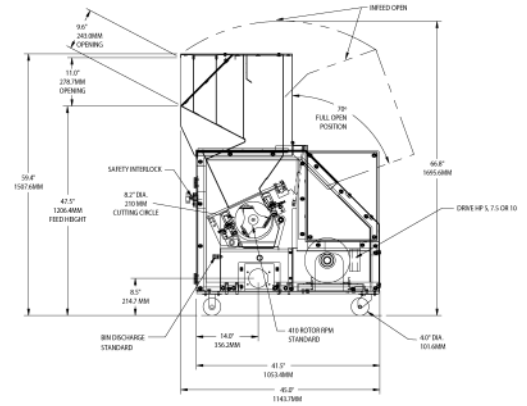
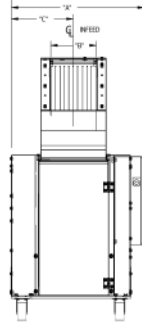

Optional Feed Chute Drawings

Specifications			
Model	810x	814x	818x
Cutting Circle	8.2" dia. (210mm)		
Avg Throughput (lbs/hr)	123	172	221
Cutting Chamber	8" x 10"	8" x 14"	8" x 18"
Rotor Knives	3-knife open-scooped with rotating end discs		
Discharge	Manual bin standard		
Motor	5HP (3.75 kW) TEFC standard		
Base	Full machine sound enclosure with casters		
Electrical Components	Start/stop button, with complete safety interlocks		
Controls	NEMA type 12		
Feed Height (manual chute)	47.5" (1206mm)		
Feed Height (front robot/conveyor chute)	59.1" (1502mm)		
Feed Height (rear robot/conveyor chute)	68.6" (1742mm)		
Overall Height (manual chute model)	59.4" (1507mm)		
Overall Length	45.0" (1144mm)		
Overall Width	30.3" (770mm)	34.3" (871mm)	38.3" (973mm)
Weight	1220 lbs	1400 lbs	1610 lbs