



Technical Specifications

800X Series Beside-the-Press Granulators



Standard Features:

All 800X Series Beside-the-Press granulators come standard with:

- Hopper
 - Hand, Feed hopper with modular access points for feed chute installation
 - Sound attenuated
- Cutting Chamber
 - Offset design, 2 bed knives
 - Machined, bolted, and doweled
 - Fully sound-attenuated to approximately 70-80 dBA
- 3-Knife Rotor
 - Open-scooped with rotating end discs
- Quick-release Hand Knob access
- Rotor and Bed Knives
 - D2 OEM manufactured
 - Proprietary Heat Treating Process
- Pivoting drop-down screen and screen cradle
 - 1/4" standard, 3/16", 5/16", 3/8" and other sizes available
- 5 HP TEFC motor and solid flywheel drive
- Standard metal bin discharge

Options			
Model	810X	814X	818X
Cutting Circle	8.2" dia. (210mm)		
Avg Throughput (lbs/hr)	123	172	221
Cutting Chamber	8" x 10" (203mm x 254mm)	8" x 14" (203mm x 356mm)	8" x 18" (203mm x 457mm)
Rotor Knives	3-knife open-scooped with rotating end discs		
Discharge	Manual bin standard		
Motor	5HP (3.75 kW) TEFC standard		
Base	Full machine sound enclosure with casters		
Electrical Components	Start/stop button, with complete safety interlocks		
Controls	NEMA type 12		
Feed Height (manual chute)	47.5" (1206mm)		
Feed Height (front robot/conveyor chute)	59.1" (1502mm)		
Feed Height (rear robot/conveyor chute)	68.6" (1742mm)		
Overall Height (manual chute model)	59.4" (1507mm)		
Overall Length	45.0" (1144mm)		
Overall Width	30.3" (770mm)	34.3" (871mm)	38.3" (973mm)
Weight	1220 lbs (553 kgs)	1400 lbs (635 kgs)	1610 lbs (730 kgs)



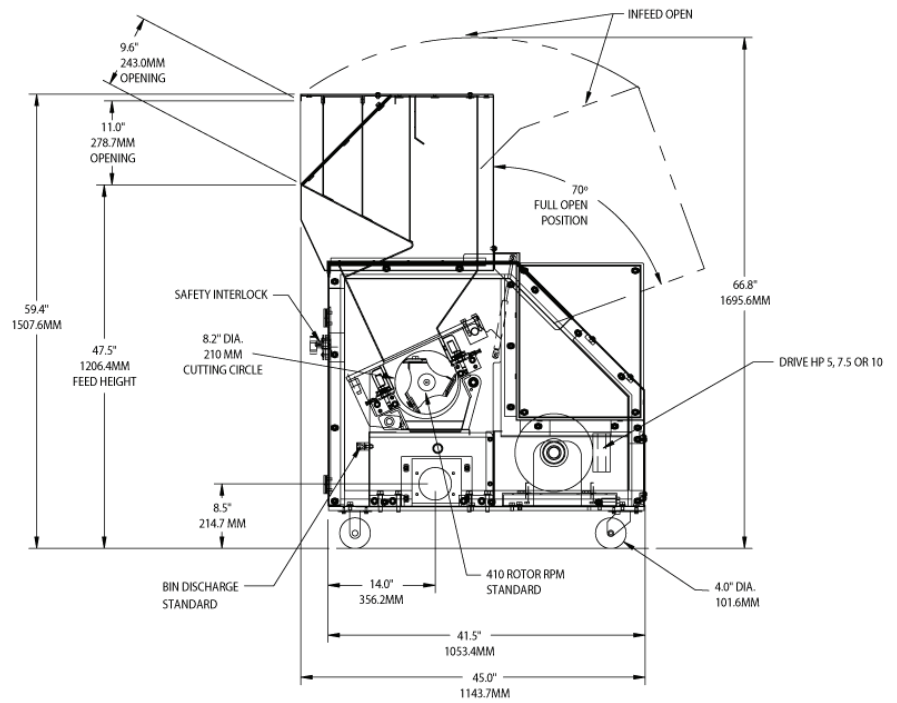
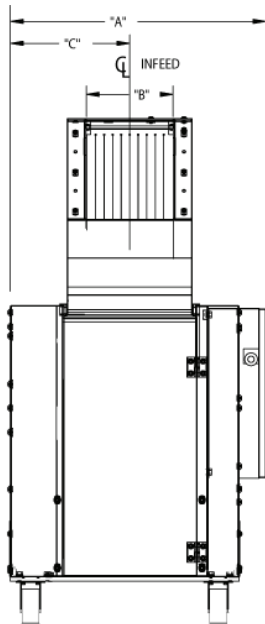

Machine Model	A	B	C	D
810	30.3" (770mm)	10.2" (260mm)	14.3" (363mm)	16.5" (420mm)
814	34.3" (871mm)	14.2" (360mm)	16.3" (414mm)	20.5" (520mm)
818	38.3" (973mm)	18.2" (462mm)	18.3" (465mm)	24.5" (622mm)